

Complete Measuring Guide

How To Order Your Custom Drive Shaft As Easy As 1-2-3

Step 1a:

Select The Type Of Drive Shaft.

***Modified vehicles may require a different type than original.**

Type A Double Cardon (CV)
 May have flange or yoke attachment at either end.

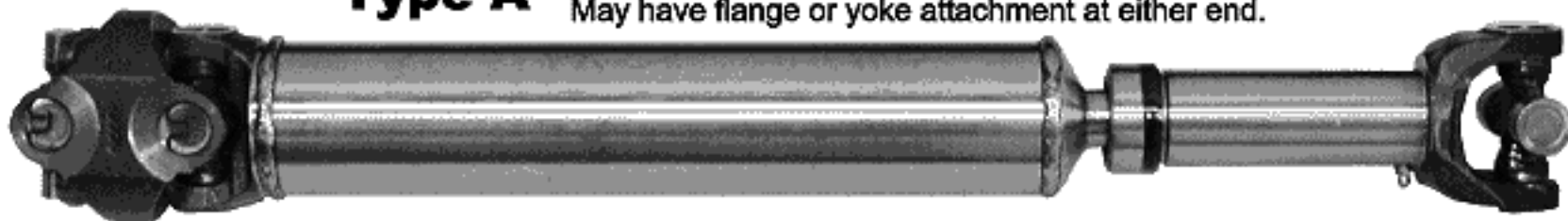

Type B Standard Slip - 2 Joint
 May have flange or yoke attachment at either end.

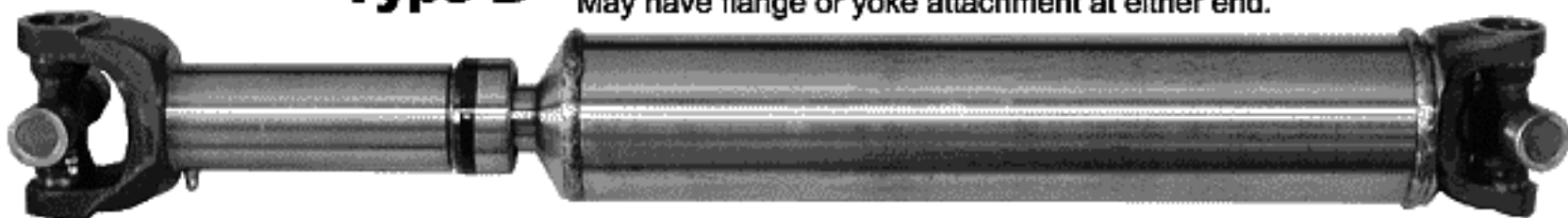

Type C Reverse Slip - 2 Joint
 May have flange attachment at differential end.

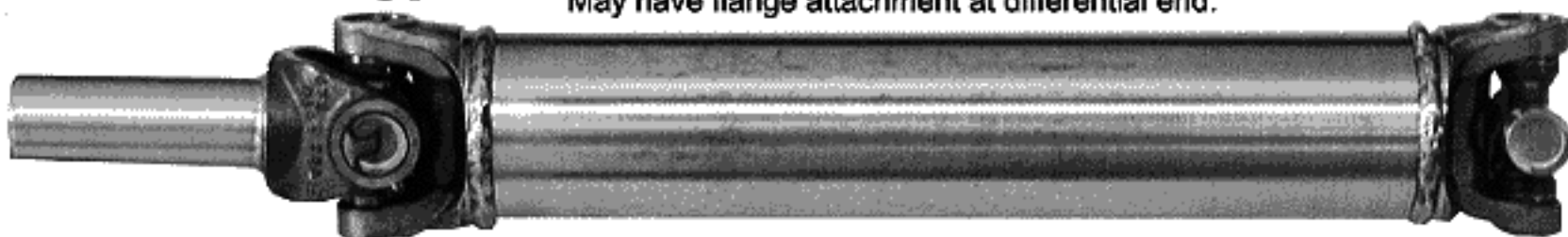

Step 1b:

Select The Tube Diameter.

***Modified vehicles may require a different tube than original.**

You must consider the length of the drive shaft, expected speed in RPM (revolutions per minute) and obstructions that may limit tube diameter.



Most Stock Applications:

The original equipment diameter will be sufficient.

Non-Stock Applications:

Here are our general guidelines for the minimum tube diameter based on drive shaft length, center of joint to center of joint installed at an expected maximum operating speed of 3,000 RPM (revolutions per minute) or less. Larger tubes will allow for higher speed and in most cases greater strength, but may create clearance problems.

Tube Diameter	Drive Shaft Maximum Length
1.250"	35"
2.000"	45"
2.500"	50"
2.750"	55"
3.000"	60"
3.500"	70"

Step 1c:

Select The Spline Type For A & B Only.

***Modified vehicles may require a different spline than original.**
Splines are available for a variety of specialty purposes.

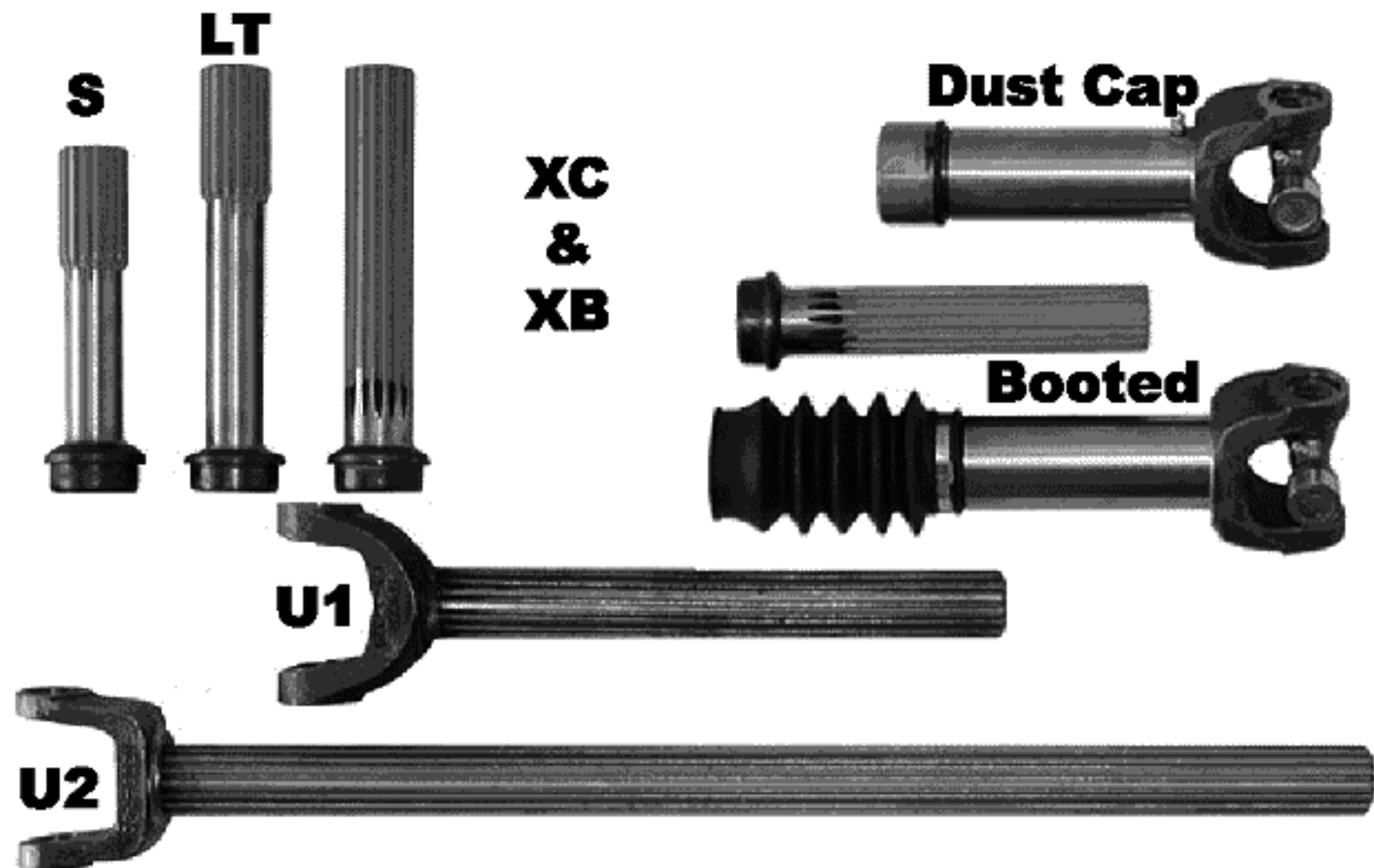

(S) Standard Spline:

Used on most original equipment applications and will generally allow for a useable stroke of 3" Can be used in all tube diameters and is the lowest priced.

(LT) Long Travel Spline:

Very similar to the (S) Standard Spline, but is 1" longer to allow for a useable stroke of about 4". Can be used on 2", 2.5", 2.75", 3", & 3.5" diameter tubes.

(XB & XC) Extended Life Splines:

Advantages is a longer stroke than the (S) Standard Spline. The splines are cut for the full length of the stub. This yields more contact area between the slip yoke & spline stub that will net a longer life. Usable stroke is 4.5". The XC comes with a dust cap and the XB comes with a boot. The XC can be used on 1.25" & 2" diameter tubes. The XB can be used on 2" diameter tubes.

(U1 & U2) Ultimate Travel Splines:

Specifically designed for applications such as shackle reversals in conjunction with revolver shackles or buggy springs. The U1 has a useable stroke of 8" and the U2 has a useable stroke up to 19". **Not recommended for high-speed use.** Can be used in all tube diameters but is most suitable for 2" diameter tubes.

Step 2

*Note: For the most accurate measurements please use a caliper.

Determine The Attachment For Each End.

*This step may not be required for pure stock applications.

Choice #1 - End Yoke / U-Joint:

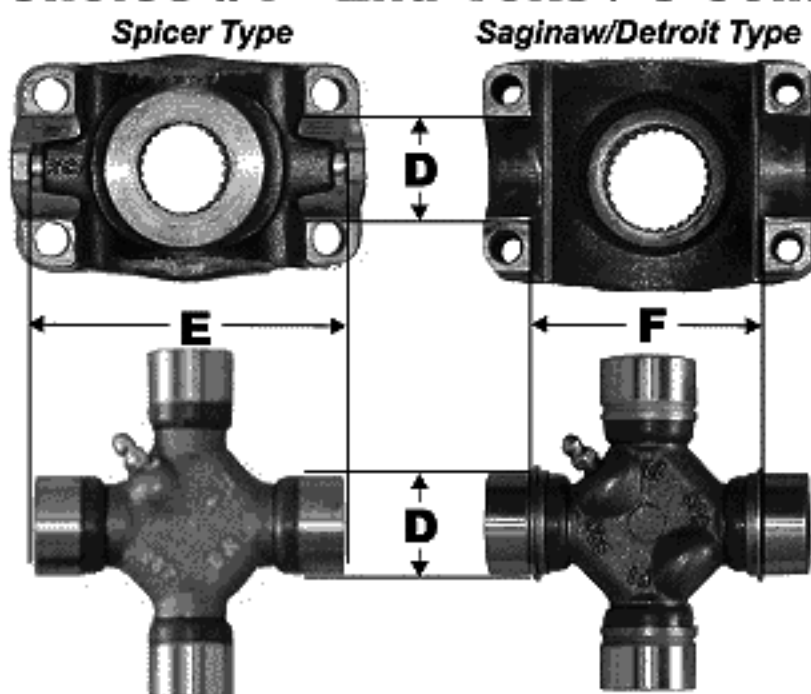

How To Measure:

Measure the attaching yoke or U-Joint. Note the differences between yokes. Spicer has centering lugs. Saginaw or Detroit are broached flat on inside surface. Yoke dimensions D, E or F match D, E or F on U-Joint. With Spicer yokes/joints, dimension E equals the distance between centering lugs or the width across the U-Joint. On Saginaw or Detroit yokes/joints dimension F equals the inside span of the yoke or the distance between the snap rings outside edge.

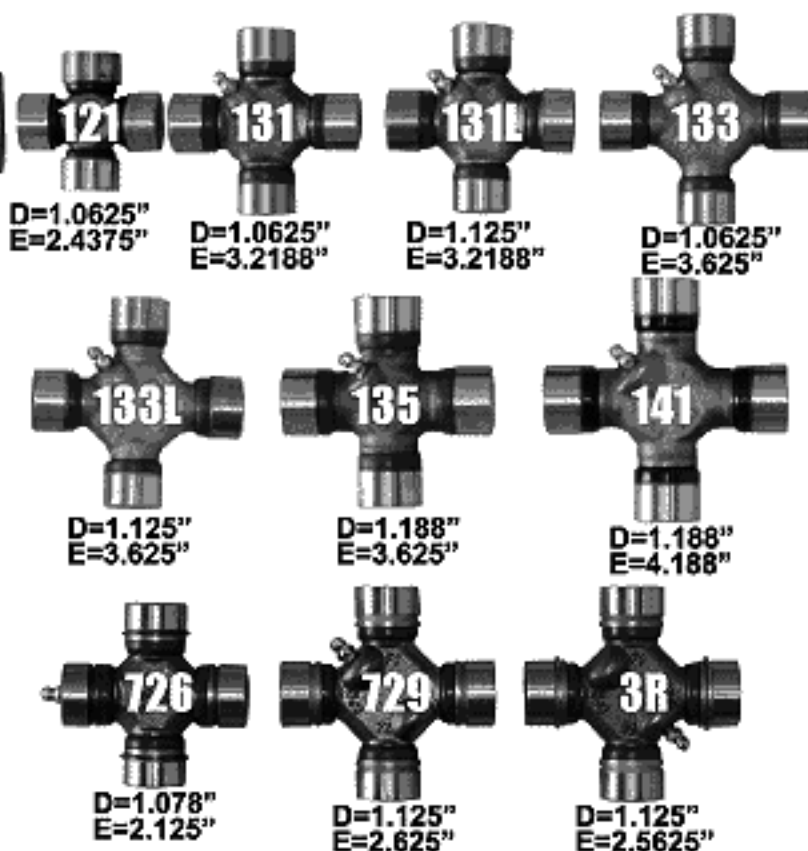

Universal Joint Selection

Universal joints are categorized by their method of retention (inside or outside snap rings) and their physical dimensions. These different sizes are generally referred to as their **SERIES** name.

It will almost always be necessary to confirm the universal joint series in order to properly build your drive shaft. In many custom applications there may be a possibility of increasing the universal joint size for greater strength.

Each series will also have a strength and life expectancy rating. The expected life rating will be assuming proper maintenance, a constant load and constant speed operating angle. Given all of these variables, life expectancy can be impossible to determine in any but the broadest range. **We suggest keeping the stock universal joint series on all but highly modified vehicles.** On modified vehicles it is best to select universal joint size for strength based on ultimate expected torque and the universal joints. Strength ratings for the following universal joints are shown in pound feet torque at a minimum elastic limit.

Series Strength LB/FT

1310	1600
1330	1800
1350	2200
1410	2800

U-Joint Choices:

121	1210 SERIES U-JOINT D=1.0625" E=2.4375"
131	1310 SERIES U-JOINT D=1.0625" E=3.2188"
131L	1310 SERIES LARGE CAP D=1.125" E=3.2188"
133	1330 SERIES U-JOINT D=1.0625" E=3.625"

If horsepower and drive shaft speed in RPM are known, torque can be calculated as follows:

$$\text{TORQUE (FT/LB)} = \text{HP} \times 5252 / \text{RPM}$$

EXAMPLE: 100 HP X 5252 / 1500 RPM = 350 FT/LB torque

133L	1330 SERIES LARGE CAP D=1.125" E=3.625"	726	7260 SERIES U-JOINT D=1.078" F=2.125"
135	1350 SERIES U-JOINT D=1.188" E=3.625"	729	7290 SERIES U-JOINT D=1.125" F=2.625"
141	1410 SERIES U-JOINT D=1.188" E=4.188"		
3R	3R SERIES U-JOINT D=1.125" F=2.5625"		

Choice #2 - Flanges

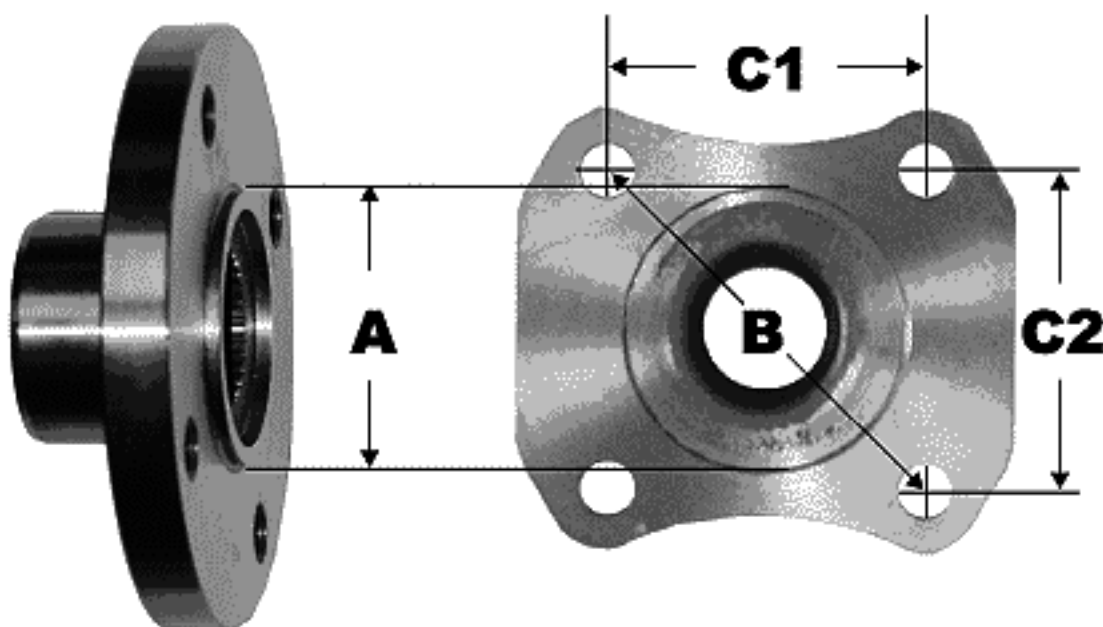

How To Measure:

Measure the pilot diameter dimension (A). Measure bolt circle diameter (B). Measure chord lengths (C1 & C2). Determine if bolt holes on the flange attached to the drive shaft are threaded or non-threaded.

Flange Choices:

F0	F0 FLANGE FOR 1210 SERIES U-JOINT	A=2"	B=3.5"	C=2.5"
F1	F1 FLANGE FOR 1310 SERIES U-JOINT	A=2"	B=3.5"	C=2.5"
F2	F2 FLANGE FOR 1310 SERIES U-JOINT	A=2"	B=4.25"	C=3"
F3	F3 FLANGE FOR 1330 SERIES U-JOINT	A=2"	B=4.25"	C=3"
F4	F4 FLANGE FOR 1350 SERIES U-JOINT	A=2"	B=4.25"	C=3"
F5	F5 FLANGE FOR 1350 SERIES U-JOINT	A=2.688"	B=4.25"	C=3"
F5T	F5 FLANGE FOR 1350 SERIES U-JOINT THREADED BOLT HOLES	A=2.688"	B=4.25"	C=3"
F6	F6 FLANGE FOR 1350 SERIES U-JOINT	A=2.75"	B=3.75"	C1=2.875" C2=2.406"
F7	F7 FLANGE FOR 1410 SERIES U-JOINT	A=2.75"	B=3.75"	C1=2.875" C2=2.406"
F8	F8 FLANGE FOR 1410 SERIES U-JOINT	A=2.688"	B=4.25"	C=3"
F8T	F8 FLANGE FOR 1410 SERIES U-JOINT THREADED BOLT HOLES	A=2.688"	B=4.25"	C=3"
DIN	LAND ROVER or EARLY JEEP FLANGE FOR 1310 SERIES U-JOINT	A=2.375"	B=3.125"	C1=2" C2=2.375"
GM1	GM1 SAGINAW FLANGE FOR 3R SERIES U-JOINT	A=3.125"	B=4.25"	C=3"
GM2	GM2 SAGINAW FLANGE FOR 1310 SERIES U-JOINT	A=3.125"	B=4.25"	C=3"
GM3	GM3 SAGINAW FLANGE FOR 1330 SERIES U-JOINT	A=3.125"	B=4.25"	C=3"
S1	SUZUKI 1ST DESIGN FLANGE	A=1.774"	B=3.13"	C1=2.225" C2=2.225"
S2	SUZUKI 2ND DESIGN FLANGE	A=1.774"	B=3.35"	C1=2.375" C2=2.375"
LC1	LAND CRUISER 1ST DESIGN 3 SPEED FLANGE FOR 1310 SERIES U-JOINT 10 MM BOLT HOLES	A=1.812"	B=3.375"	C1=2.225" C2=2.55"
LC2	LAND CRUISER 2ND DESIGN 4 SPEED CV FLANGE FOR 1310 SERIES U-JOINT 11.5 MM BOLT HOLES	A=1.812"	B=3.575"	C1=2.71" C2=2.375"
T1	TOYOTA TRUCK 1ST DESIGN FLANGE FOR 1310 SERIES U-JOINT 8MM HOLES	A=1.812"	B=3.35"	C1=2.225" C2=2.52"
TA1	TOYOTA TRUCK 1ST DESIGN CV FLANGE FOR 1310 SERIES U-JOINT 8 MM HOLES	A=1.812"	B=3.58"	C1=2.75" C2=2.375"
T2	TOYOTA TRUCK 2ND DESIGN FLANGE FOR 1310 SERIES U-JOINT 10MM HOLES	A=1.812"	B=3.35"	C=2.375"
Ta2	TOYOTA TRUCK 2ND DESIGN CV FLANGE FOR 1310 SERIES U-JOINT 10MM HOLES	A=1.812"	B=3.58"	C1=2.725 C2=2.375"



How To Measure:

On female slip yoke applications count the number of teeth on the spline (G).. Measure the spline diameter (H) and seal surface diameter (I). On Male slip yoke applications count the number of teeth on the spline (G). Measure the spline diameter (H).

Slip Yokes:

27Z131	27 SPLINE SLIP YOKE FOR 1310 SERIES U-JOINT	G=27	H=1.172"	I=1.5
27Z131C	27 SPLINE CV SLIP YOKE FOR 1310 SERIES U-JOINT	G=27	H=1.172"	I=1.5
27Z133	27 SPLINE SLIP YOKE FOR 1330 SERIES U-JOINT	G=27	H=1.172"	I=1.5
27Z135	27 SPLINE SLIP YOKE FOR 1350 SERIES U-JOINT	G=27	H=1.172"	I=1.5
27Z3R	27 SPLINE SLIP YOKE FOR 3R SERIES U-JOINT	G=27	H=1.172"	I=1.5
31Z131	31 SPLINE SLIP YOKE FOR 1310 SERIES U-JOINT	G=31	H=1.390	I=1.886
31Z133	31 SPLINE SLIP YOKE FOR 1330 SERIES U-JOINT	G=31	H=1.390	I=1.886
31Z133C	31 SPLINE CV SLIP YOKE FOR 1330 SERIES U-JOINT	G=31	H=1.390	I=1.886
31Z135	31 SPLINE SLIP YOKE FOR 1350 SERIES U-JOINT	G=31	H=1.390	I=1.886
31Z135C	31 SPLINE CV SLIP YOKE FOR 1350 SERIES U-JOINT	G=31	H=1.390	I=1.886
32Z131	32 SPLINE SLIP YOKE FOR 1310 SERIES U-JOINT	G=32	H=1.378	I=1.875
32Z133	32 SPLINE SLIP YOKE FOR 1330 SERIES U-JOINT	G=32	H=1.378	I=1.875
32Z135	32 SPLINE SLIP YOKE FOR 1350 SERIES U-JOINT	G=32	H=1.378	I=1.875
32Z135C	32 SPLINE CV SLIP YOKE FOR 1350 SERIES U-JOINT	G=32	H=1.378	I=1.875
32Z141	32 SPLINE SLIP YOKE FOR 1410 SERIES U-JOINT	G=32	H=1.378	I=1.875
32Z3R	32 SPLINE SLIP YOKE FOR 3R SERIES U-JOINT	G=32	H=1.378	I=1.875
32Z3RC	32 SPLINE CV SLIP YOKE FOR 3R SERIES U-JOINT	G=32	H=1.378	I=1.875
32ZM131C	32 MALE SPLINE CV YOKE SHAFT FOR 1310 SERIES U-JOINT	G=32	H=1.378	
32ZM3R	32 MALE SPLINE YOKE SHAFT FOR 3R SERIES U-JOINT	G=32	H=1.378	

Step 3:

Determine The Proper Working Length.

***Pick a drawing.**

Standard Applications:

Measure with weight on the suspension.

Reverse Shackle, Revolver Shackle and Buggy Spring Applications:

Measure fully compressed and fully extended.

